

## High Precision Punch Formers

Tangential Style – 1-1/4" Capacity

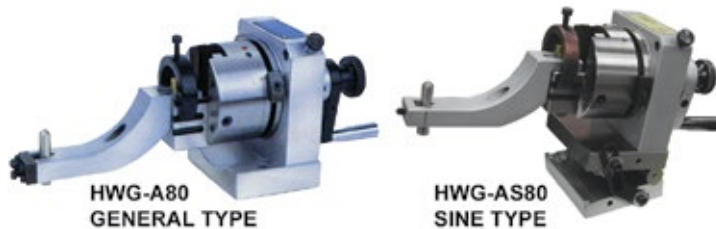

- Maximum diameter of workpiece: 1-1/4"
- Indexing  $\pm 10$  seconds: 24 (15°)
- Parallelism: 0.0001"
- Squareness: 0.0001"

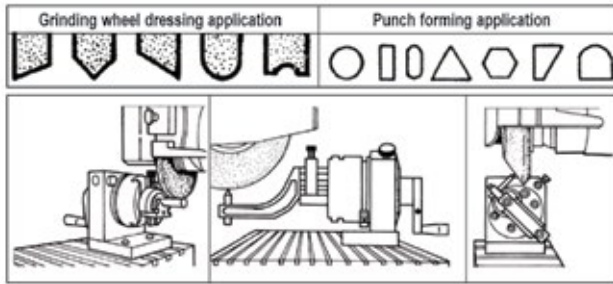

Model	Type	Center Height	Weight (lbs)	Code
HWG-A80	General	3.15	18	875510
HWG-AS80	Sine	4.49	25	875511

## ER Collet Style Punch Formers

ER32 – 1/8" to 3/4" Capacity



NOTE: Collets not included

- Indexing  $\pm 10$  seconds: 24 (15°)
- Through hole: 3/4"
- Parallelism: 0.0001"
- Squareness: 0.0001"

Diameter Range (Inch)	Center Height (Inch)	Weight (lbs)	Code
0.04 - 0.78	3.15	15	875520
0.04 - 0.78	4.49	21	875521

## Chuck Style Punch Formers

2" Capacity

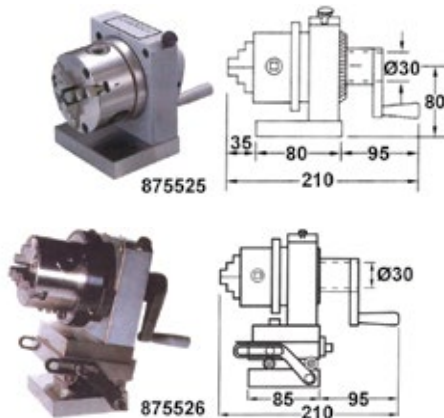

- Maximum diameter of workpiece: 2"
- Indexing  $\pm 10$  seconds: 24 (15°)
- Through hole: 3/4"
- Parallelism: 0.0001"
- Squareness: 0.0001"

Center Height (Inch)	Weight (lbs)	Code
3.15	18	875525
4.49	25	875526