

Toggle Clamps & Accessories

(continued)

Vertical Handle Toggle Clamps

- Holding capacity: 340 kg (750 lbs) maximum
- Weight: 624 g (1 lb, 6 oz)
- Handle moves 58°, bar 105°
- Accepts all 3/8-16 diameter spindles
- U-Bar supplied with two flanged washers
- Solid bar supplied (spindle not included)
- Vinyl hand grip

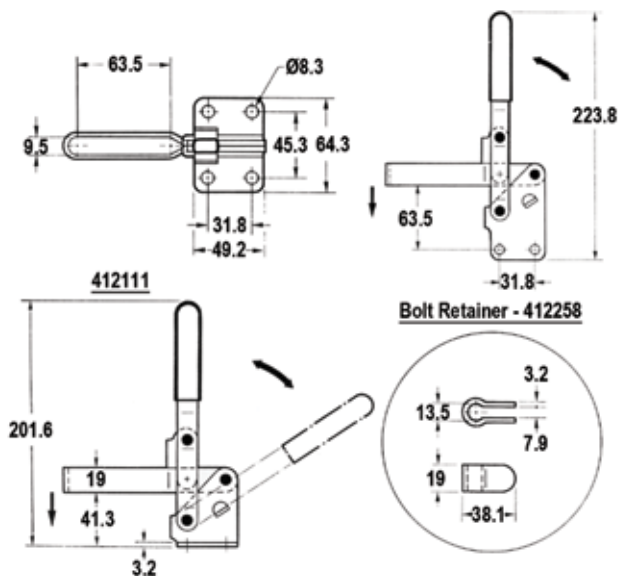

Model	Description	Code
12265	U-bar, flanged base, straight handle	412111
12275	Solid bar, flanged base, straight handle	412113
12280	Solid bar, straight base, straight handle	412114

Vertical Handle Toggle Clamps

- Heavy duty
- Compact size
- Two stops provide user with a choice of handle and bar movement
- Holding capacity: 450 kg (1000 lbs) maximum
- Weight: 1250 g (44 oz)
- Handle moves 58°, bar 100° (with roll pin)
- Handle moves 70°, bar 135° (without roll pin)
- Accepts all 1/2 - 13 diameter spindles
- U-Bar supplied with two flanged washers
- Solid bar (spindle not included)
- Vinyl hand grip
- Hardened bushings
- Removable ground pins

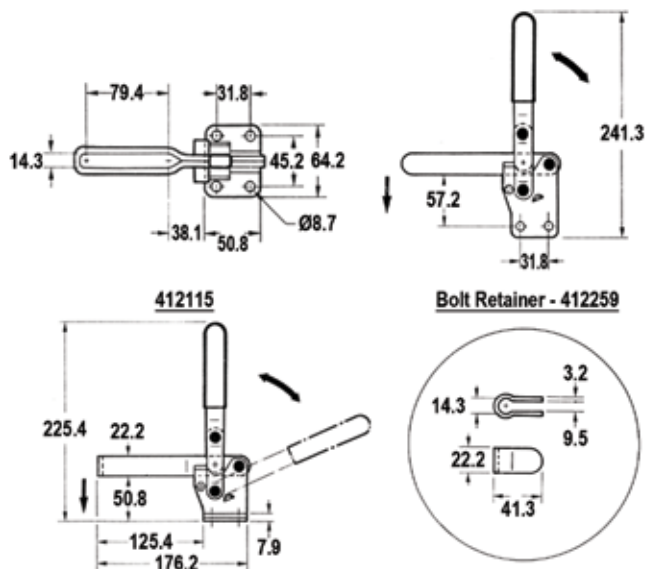

Model	Description	Code
10247	U-bar, flanged base, straight handle	412115
10249	Solid bar, flanged base, straight handle	412117
10250	Solid bar, straight base, straight handle	412118

CLAMPING COMPONENTS