

Horizontal Milling Attachments

R8 & ISA40

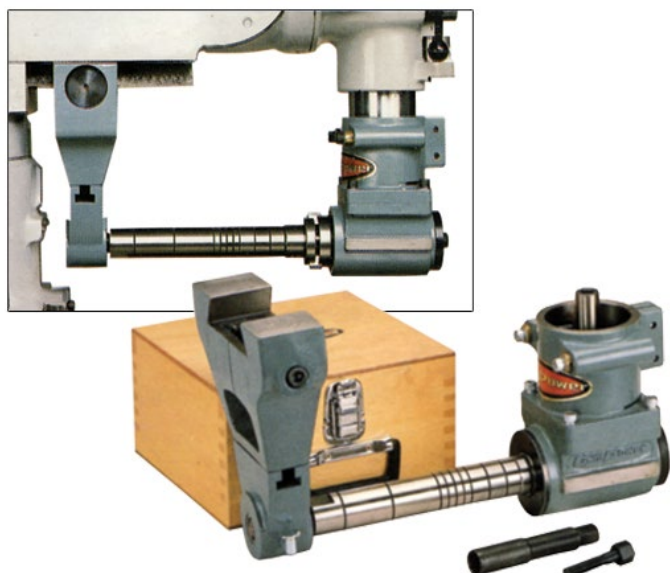

Available only as a set

Spindle	Code
R8	264101
*ISA40	264103

*Please specify quill diameter and dovetail width

Right Angle Head

Taper	Suitable Milling Head Quill Diameter
R8	85.725 mm – 86 mm = 3.38"
NT40	85.725 mm – 115 mm = 3.38" – 4.53"

Horizontal Milling Arbor Support

Taper	Suitable Milling Head Quill Diameter
R8	85.725 mm – 86 mm = 3.38"
NT40	85.725 mm – 115 mm = 3.38" – 4.53"

Right Angle Heads

R8 & ISA40



- For horizontal cutting on vertical machines
- Rigid construction

Spindle Taper	Tool Taper	Quill Diameter (Inch)	Code
R8	R8	3.375/3.385	264105
*ISA40	R8	*3.375/4.520	264107

*Please specify quill diameter and dovetail width

Tail Stock

Rigid & Precision Designed



Set includes:

- Precision dead center with 0.0002" T.I.R.
- 2 locating keys
- 2 mounting bolts with T-nuts

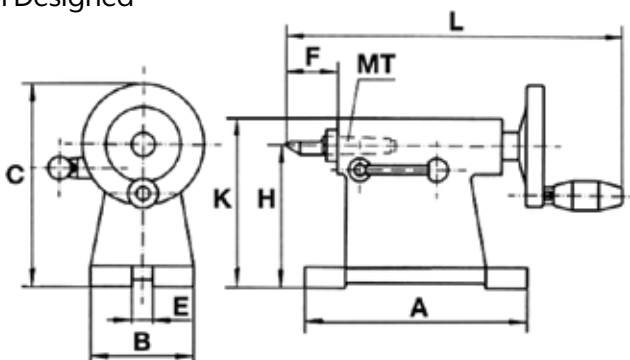

H + 0002" (Inch)	K (Inch)	B (Inch)	A (Inch)	F Minimum (Inch)	F Maximum (Inch)	E Key Size (Inch)	Morse Taper	Weight (lbs)	Code
3.937	5.51	3.15	7.68	1.30	2.48	0.55	MT2	14	277111
4.921	7.01	3.54	7.68	1.54	2.72	0.55	MT2	16	277112
6.299	8.39	4.53	9.84	1.89	3.35	0.71	MT3	28	277113
9.843	11.93	5.91	11.02	2.34	3.92	0.71	MT4	51	277114