

## Live Centers - High RPM Sprint

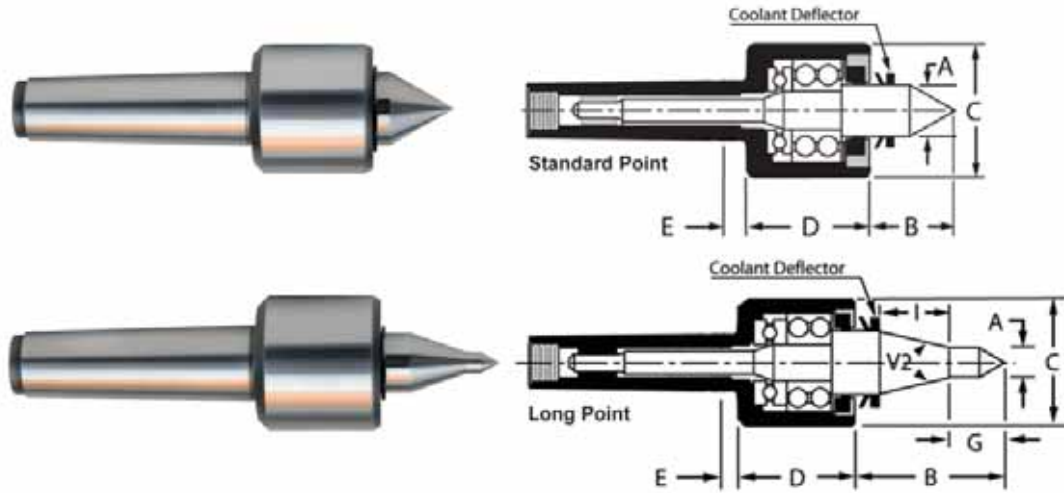

### Standard Point and Long Point (CNC)



- Accuracy guaranteed to  $\pm 0.00004''$
- Coolant deflectors for additional protection from contamination
- Points through-hardened to 61-63 HRC
- Body heat-treated for additional strength

#### Standard Point

Morse Taper	A (Inch)	B (Inch)	C (Inch)	D (Inch)	E (Inch)	Maximum RPM	Workpiece Weight (lbs)	Code
2	13/16	1-1/4	2-1/8	2	3/8	6000	440	100359
3	13/16	1-3/8	2-1/8	2	3/8	6000	1100	100360
4	1-13/64	1-13/16	2-3/4	2-5/16	3/8	4000	2100	100361
5	1-29/64	2-3/8	3-1/8	2-7/16	3/8	4000	2910	100362

#### Long Point (CNC)

Morse Taper	A (Inch)	B (Inch)	C (Inch)	D (Inch)	E (Inch)	G (Inch)	V2	I (Inch)	Maximum RPM	Workpiece Weight (lbs)	Code
2	3/8	2	2-1/8	2	3/8	3/4	30°	1-19/32	6000	310	100350
3	3/8	2	2-1/8	2	3/8	3/4	30°	1-19/32	6000	310	100351
4	1/2	2-1/2	2-3/4	2-5/16	3/8	15/16	30°	2-1/4	4000	1100	100352
5	1/2	2-1/2	3-1/8	2-7/16	3/8	15/16	44°	2-1/8	4000	1100	100353