

Modular System Vises

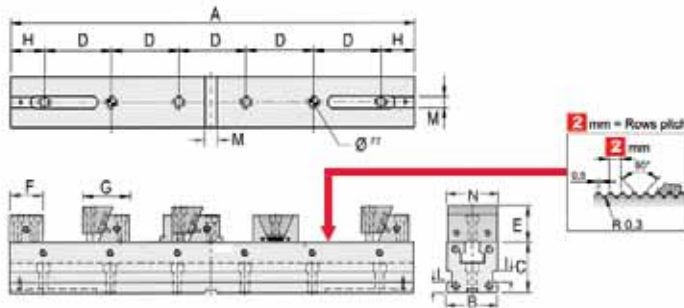

Multiflex Series Vise - Type 2



A new concept in modular clamping systems able to maximize the machine table capacity and increase its productivity. The comb system is used between the fixed and movable jaws, increasing and improving the clamping capacity.

- Modular design for easy interchangeability
- Hardened and ground steel
- Manufactured under rigid quality control
- Smooth jaws
- For multiple clamping of up to 12 work pieces of various sizes
- Supplied with one fixed jaw, four fixed-movable jaws, one "T" wrench, one pair of positioning key nuts and four workstops

A (Inch)	B -0 -0.2 (Inch)	C -0 -0.2 (Inch)	D (Inch)	E (Inch)	F (Inch)	G (Inch)	H (Inch)	I (Inch)	L (Inch)	M (Inch)	N (Inch)	Approximate Weight (kg/lbs)	Code
19.7	3	3	3.9	1.6	2	2.8/3	2	0.6	0.8	0.6	2.9	26/57	278100

Multitasking Series Vise - Type 2

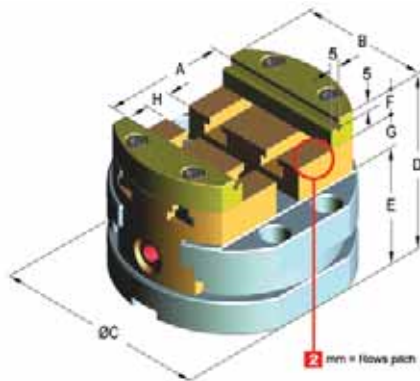

- Modular design for easy interchangeability
- Hardened and ground steel
- Manufactured under rigid quality control
- Manual operation, mechanical clamping
- Jaw adjustment in steps of 2mm (multi-axis self-centering)
- Precision hardened (HRC 60) and ground steel construction
- Gripping accuracy within 0.015mm
- Solid, rigid construction for minimum deflection
- Supplied with #2 jaws with step 5x5mm and one hexagon wrench

A (Inch)	B (Inch)	C (Inch)	D (Inch)	E (Inch)	F (Inch)	G (Inch)	H (Inch)	Approximate Weight (kg/lbs)	Code
4.1	3.9	6.3	4.5	2.8	0.8	1	1.6	11/24.3	278102