

## Saw Arbors

### Slitting and Slotting Saws

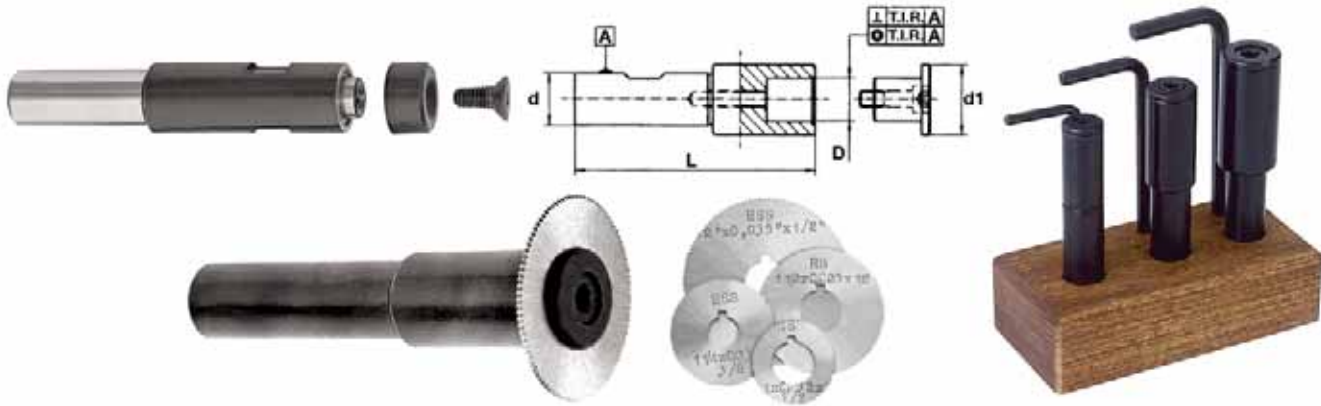

- Hardened and precisely ground
- Rigid arbors with extended length can reach areas that standard short arbors cannot
- Each arbor is ground for precision within 0.002" on diameter and 0.0004" T.I.R. (see drawing and table)
- Super low profile cup allows cutter to get closer to working area
- Plug style cup gives extra support and rigidity when working with larger diameter saws

#### 0.002" T.I.R.

d Shank Diameter (Inch)	D Hole Size (Inch)	d1 (Inch)	L (Inch)	Code	d Shank Diameter (Inch)	D Hole Size (Inch)	d1 (Inch)	L (Inch)	Code
0.500	0.250	0.500	2.700	602362	0.750	0.625	1.000	3.530	602366
0.500	0.375	0.625	2.880	602363	0.750	1.000	1.500	3.780	602367
0.500	0.500	0.750	3.070	602364	0.750	1.250	1.750	4.030	602368
-	3-Piece Set	-	-	602365	-	3-Piece Set	-	-	602369

#### 0.0004" T.I.R.

d Shank Diameter (Inch)	D Hole Size (Inch)	d1 (Inch)	L (Inch)	Code	d Shank Diameter (Inch)	D Hole Size (Inch)	d1 (Inch)	L (Inch)	Code
0.500	0.250	0.500	2.700	602370	0.750	0.625	1.000	3.530	602374
0.500	0.375	0.625	2.880	602371	0.750	1.000	1.500	3.780	602375
0.500	0.500	0.750	3.070	602372	0.750	1.250	1.750	4.030	602376
-	3-Piece Set	-	-	602373	-	3-Piece Set	-	-	602377

### Weldon and R8 Shanks



- Rigid and precision design
- This versatile arbor offers flexibility in sawing operations
- The spring loaded mechanism accepts saw blades with hole diameters from 1/2" to 1"
- The saw blades are firmly secured in position with a hex socket screw
- Rust resistant, black oxide finish
- Arbors are provided with one hex wrench and one screw

Shank Size	Hole Sizes (Inch)	Overall Length (Inch)	Code	Shank Size	Hole Sizes (Inch)	Overall Length (Inch)	Code
1/2" Weldon	1/2, 5/8, 3/4, 7/8, 1	2-9/16	417170	R8	1/2, 5/8, 3/4, 7/8, 1	5-3/32	602378