

Electronic Screw Thread Micrometers

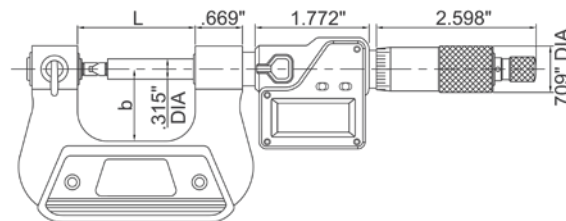

MICROMETERS

- Measures pitch diameter of screw threads
- Resolution: 0.00005"/0.001mm
- Button function: on/off, set, inch/mm, ABS/INC
- Data output
- Battery LR44
- Auto power off
- Non-rotating spindle
- Ratchet stop
- Supplied with 60° setting standards
- Supplied in fitted storage case

| Range (Inch/mm) | L (Inch) | b (Inch) | INSIZE No. | Code |
|-----------------|----------|----------|------------|--------|
| 0-1/0-25mm | 1.654 | 1.024 | 3581.25E | 877166 |

Accuracy of micrometers with tips

| Pitch | Range 0-1" |
|----------|------------|
| 64-48TPI | ±0.0004" |
| 44-32TPI | ±0.0004" |
| 28-20TPI | ±0.00045" |
| 18-13TPI | ±0.00055" |
| 12-7TPI | ±0.00065" |
| 6-3.5TPI | - |

Deep Throat (Sheet Metal) Micrometers



- Deep frame suitable for deep throat, paper and plastic
- Graduation: 0.0001"
- Ratchet stop
- Supplied in fitted storage case

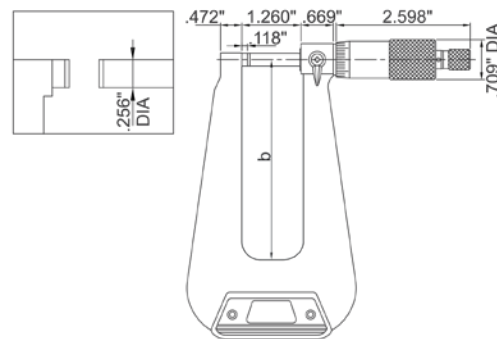

| Range (Inch) | Accuracy (Inch) | b (Inch) | INSIZE No. | Code |
|--------------|-----------------|----------|------------|--------|
| 0-1 | ±0.0003 | 6.102 | 3239-13 | 281235 |
| 0-1 | ±0.0004 | 12.205 | 3239-14F | 281251 |

Micrometer Head



- Meets DIN863-2 standards
- Graduation: 0.01mm
- Ratchet stop



| Range (mm) | Stem | Spindle Tip | Accuracy | INSIZE No. | Code |
|------------|-------|----------------|----------|------------|--------|
| 0-25 | Plain | Flat (Carbide) | 3µm | 6381-25W | 282605 |